

BIXOLON®

User's Manual
XM7-20

MOBILE PRINTER
Ver. 1.00



<http://www.bixolon.com>

Introduction

The XM7-20 is a 2-inch thermal mobile label printer which simultaneously connects over WIFI, Bluetooth, or Dual(WLAN & Bluetooth) Radio. Ideal for smart mobility labelling due to its compact, lightweight design with an easy-to-open peeler and LCD.

※ The main features of the printer are as follows



1. 2-inch Mobile Label Printer
2. Maximum 6ips (152 mm/s) printing speed.
3. Compact and light design 93 x 168 x 69 mm (3.66 x 6.61 x 2.72 inch) (W x D x H)
4. Peeler
5. Media holder (media width : 25 ~ 58 mm)
6. Supports various wireless connection : Bluetooth V5.0(Classic / LE), Wireless LAN 802.11 a/b/g/n, Dual Radio(Bluetooth V5.0(Classic / LE) & Wireless LAN 802.11 a/b/g/n)

It is advisable to read the contents of this manual carefully before using the printer for the first time.

※ Use only authorized supplies that can be trusted!

We are not responsible for quality and service for damage caused by the use of unauthorized supplies (or recycled ones).

Safety Information

 Warning	Warnings must be heeded carefully in order to prevent serious physical harm.
 Caution	Cautions must be heeded in order to prevent minor injuries, equipment damage, or data loss.

Symbol Information





	DC (Direct current)
	Warning, Caution
	USB
	Ethernet

Table of Contents

1. Content Confirmation	10
2. Product Part Names	10
3. Installation & Usage	12
3-1 Battery Installation.....	12
3-2 Battery Charging	12
3-2-1 Using AC/DC Adapter.....	12
3-2-2 Using USB TYPE-C (Power Delivery)	13
3-2-3 Using Single Battery Charger (Optional)	14
3-2-4 Using Quad Battery Charger (Optional)	15
3-3 Media Installation	17
3-4 Using Peeler.....	19
3-5 Using Belt Strap	20
3-6 Using Shoulder Strap (Optional)	21
3-7 Using Fan-Fold Media.....	22
3-8 Using Control Panel	23
4. Self-Test	24
5. LCD Menu.....	26
6-1 Bluetooth, Wireless LAN Connection	29
6-2 Interface Cable Connection.....	30
6-3 Fixed Interface Cable Connection	31
7. Printer Cleaning.....	32
8. Appendix	33
8-1 Specifications	33
8-2 Label Types.....	34

Manual Information

This user's manual contains basic information for product usage as well as for emergency measures that may be required.

- ※ The following separate manuals provide more detailed content on various technological issues and areas.

1. Software Manual

This manual provides information for development.
Please refer to each manual for more information.

- Windows Driver Manual
- Label Artist-II Manual
- Net Configuration Tool Manual
- Unified Label Utility-II Manual
- Android SDK Manual
- Linux SDK Manual
- Windows SDK Manual
- iOS SDK Manual

2. Bluetooth Connection Manual

This manual describes how to connect terminals (PDAs, PCs, etc.) with Bluetooth functionality.

3. Wi-Fi Connection Manual

This manual describes how to connect Wireless LAN in infrastructure or Soft AP.

4. SLCS Programming Manual

This manual provides information on the protocol and functions of the control commands that can be used with this product.

Safety Precautions

In using the present appliance, please keep the following safety regulations in order to prevent any hazard or material damage.



WARNING

Violating following instructions can cause serious injury or death.

Do not plug several products into one multi-outlet.

- This can provoke over-heating and a fire.
- If the plug is wet or dirty, dry or wipe it before usage.
- If the plug does not fit perfectly in the outlet, do not plug in.
- Be sure to use only standardized multi-outlets.

PROHIBIT

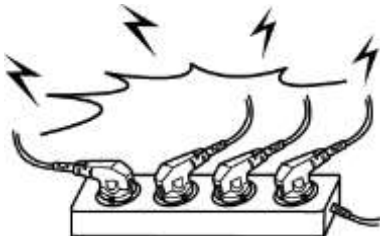

You must use only the supplied adapter.

- It is dangerous to use other adapters.

PROHIBIT



Do not pull the cable to unplug.

- This can damage the cable, which is the origin of a fire or a breakdown of the printer.

PROHIBIT



Keep the plastic bag out of children's reach.

- If not, a child may put the bag on his head.

PROHIBIT



Do not plug in or unplug with your hands wet.

- You can be electrocuted.

PROHIBIT



Do not bend the cable by force or leave it under any heavy object.

- A damaged cable can cause a fire.

PROHIBIT

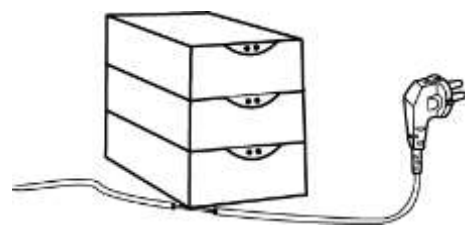



CAUTION

Violating following instructions can cause slight wound or damage the appliance.

If you observe a strange smoke, odor or noise from the printer, unplug it before taking following measures.

- Switch off the printer and unplug the set from the mains.
- After the disappearance of the smoke, call your dealer to repair it.

TO UNPLUG



Keep the desiccant out of children's reach.

- If not, they may eat it.

PROHIBIT



Install the printer on the stable surface.

- If the printer falls down, it can be broken and you can hurt yourself.

PROHIBIT

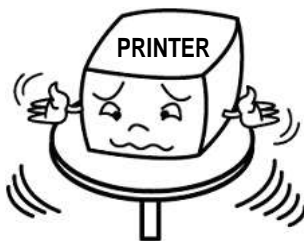

Use only approved accessories and do not try to disassemble, repair or remodel it for yourself.

- Call your dealer when you need these services.
- Do not touch the blade of the paper tear bar (or auto cutter).

DISASSEMBLING PROHIBITED



Do not let water or other foreign objects in the printer.

- If this happened, switch off and unplug the printer before calling your dealer.

PROHIBIT



Do not use the printer when it is out of order. This can cause a fire or an electrocution.

- Switch off and unplug the printer before calling your dealer.

TO UNPLUG



Battery Safety Warning

Please be sure to read this guide prior to use.

Warning

1. If the battery is not charged after the charging time, stop charging and contact the seller.
2. Store and use the battery where it will not come into contact with liquid (water, salt water, etc.). There may be a risk of overheating, rupturing or igniting.
3. Avoid exposing the battery to high temperatures over 50 °C and do not store or use it in a place with high temperature and humidity. There may be a risk of overheating, rupturing or igniting. In addition, it may reduce the performance and life of the battery. There is a risk of explosion, especially when the battery is placed by a fire or stored near a heating device (e.g., heater, etc.).
4. Do not put the battery in a microwave oven or high-pressure cooker (pressure cooker, etc.). There may be a risk of overheating, rupturing or igniting.
5. Do not use or leave the battery exposed to direct sunlight or high temperatures such as in a car. It may reduce battery performance and life, or there may be a risk of overheating, rupturing or igniting.
6. The usage temperature range of the battery is as follows. If used outside of this range, battery performance and life may be reduced, or there may be a risk of overheating, rupturing or igniting.
 - Charging: 0 to 50 °C (32 to 122 °F)
 - Using: -15 to 50 °C (5 to 122 °F)
 - Long-term storage (over 30 days): -15 to 40 °C (5 to 104 °F)
7. Be sure to only use an adapter or charger approved by us to charge the battery. Use of any other adapter or charger may reduce battery performance and life, or cause a risk of overheating, rupturing or igniting.
8. Do not use the (+) and (-) terminals of the battery reversely. Failure to use the equipment may result in an abnormal chemical reaction inside the battery, which may cause overheating, rupturing or igniting.
9. Do not touch the (+) and (-) terminals of the battery with metal. Also, do not carry or store it with metallic goods (necklaces, hair pins, coins, etc.). There may be a risk of overheating, rupturing or igniting.
10. Do not use the battery in a place where static electricity can be generated. It may damage the protective device, resulting in reduction of battery performance and life, or there may be a risk of overheating, rupturing or igniting.
11. Avoid causing any strong impact to the battery or throwing it. The protective device inside the battery may be damaged, which may reduce the battery performance and life, or there may be a risk of overheating, rupturing or igniting.

12. Do not disassemble or modify the battery. The battery contains safety and protection devices to prevent danger. It may reduce battery performance and life due to damage, or there may be a risk of overheating, rupturing or igniting.
13. If any leakage of the battery comes into contact with the eyes or skin, immediately rinse with clean water such as tap water and consult a doctor immediately.
14. Keep the battery out of the reach of children and infants. If it is swallowed, consult a doctor immediately.

Recommendations

1. Do not charge for longer than the charging time described in this guide, as it may reduce battery performance and duration.
2. If the battery is not expected to be used for a long time, remove it from the equipment and keep in a place with low humidity.
3. Be sure to turn off the power of the equipment after use. Failure to do so may reduce the performance and life of the battery.
4. Batteries that have not been used for a long time may fail to charge properly. Even if you do not use the battery for a long time, charge it at least once every 6 months before storing it.
5. If the (+) and (-) terminals of the battery are contaminated, wipe them with a dry cloth and use in a clean condition. The contamination of battery may result in unstable contact with the equipment and the power may be cut off or the battery may not be charged.

Disposal

1. When using, storing or charging the battery, if you detect any abnormality such as an odor, overheating, discoloration, deformation, leakage, etc., please remove the battery from the equipment or charger and dispose of it immediately.
2. When disposing of the battery, completely discharge it, tape the terminals with insulation, and dispose of it at a designated location according to relevant laws and regulations set by the government.

1. Content Confirmation

The following items should all be contained in the printer package.
Contact the dealer from which the purchase was made if any item is damaged and/or missing.

※ Basic items



XM7-20



Battery Pack



AC/DC Adapter



Power Cord



Belt Strap

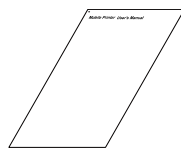

**Printer
Installation Guide**



**Media Disks
(for 12 mm (0.47 inch)
inner diameter)**

※ Optional items

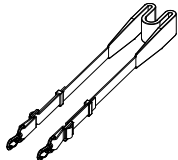

Shoulder Strap



Vehicle Adapter



**Single Battery
Charger**

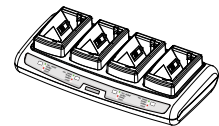

**Quad Battery
Charger**



**Serial
Interface Cable
(for Serial/USB 14pin port)**



**USB
Interface Cable
(for Serial/USB 14pin port)**



**Fixed Serial
Interface Cable
(for Serial/USB 14pin port)**



**Fixed USB
Interface Cable
(for Serial/USB 14pin port)**



Smart Battery Pack

2. Product Part Names

• Front

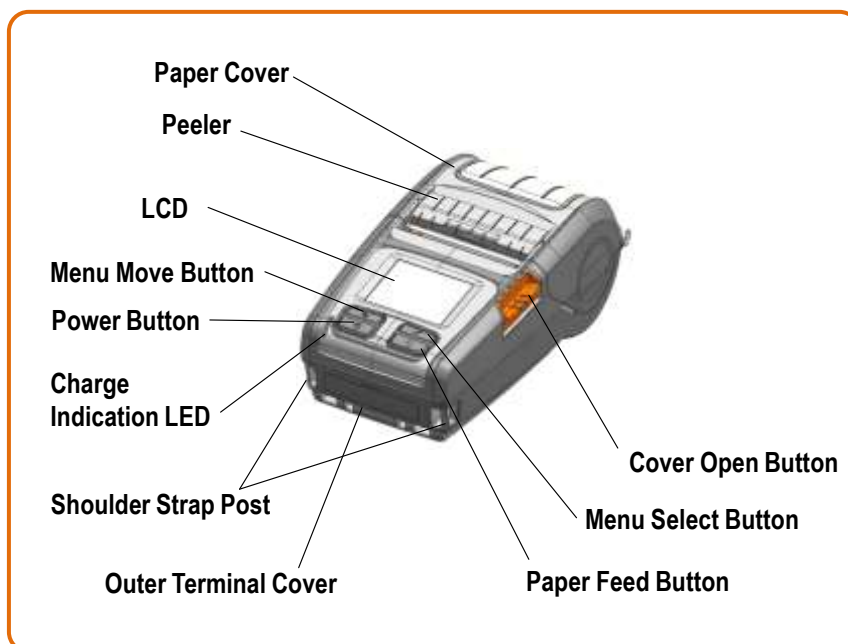

• Rear

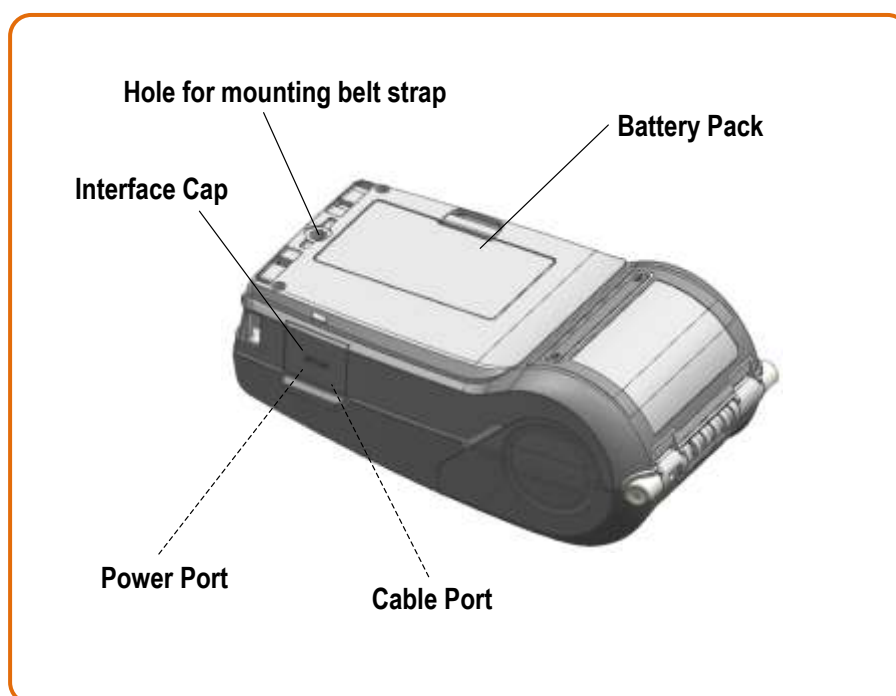

3. Installation & Usage

3-1 Battery Installation



- 1) Insert the battery in the bottom of the printer, and ensure that you align the battery hook properly.
- 2) Push the battery into the slot until you hear it snap in place.

NOTE

Since the battery is partially charged at the time of purchase, charge the battery prior to product use. (Use the AC/DC adapter or the optional Single/Quad battery charger.)

3-2 Battery Charging

3-2-1 Using AC/DC Adapter



- 1) Turn off the printer power.
- 2) Connect the power cord ② to the AC/DC adapter ① and then connect AC power.
- 3) Open the external interface cap in the direction of ③.
- 4) Connect the AC/DC adapter to the power port.

3-2-2 Using USB TYPE-C (Power Delivery)





- 1) Turn off the printer power.
- 2) Connect the AC/DC adaptor ② that supports Power Delivery function, then connect the AC power cord.
- 3) Open the external interface cap in the direction of ③.
- 4) Connect USB TYPE-C cable ① to the USB PD(Power deliver) Power adaptor, and connect the cable to the USB port.

NOTE

Battery charging status descriptions are as follows.

LED	Charge Status	Charge Time
Red LED On	Charging	Within 3 hours
Green LED On	Fully Charged	
Red LED Blinking	Error Replace or Reinstall Battery	

 Caution	The printer may incur serious damage if the AC/DC adaptor provided by BIXOLON is not used. BIXOLON is not legally liable for any such damages. (The voltage and electrical current specifications of the printer and battery charger must match.)
	Always use Power Delivery support adaptor when you use USB TYPE-C for charging. Use any other kind of adaptor may cause serious damage to the printer. Bixelon will not be responsible for damage caused by any other kind of adaptor used on this printer
 Warning	Turn off the power before charging the battery for the printer.

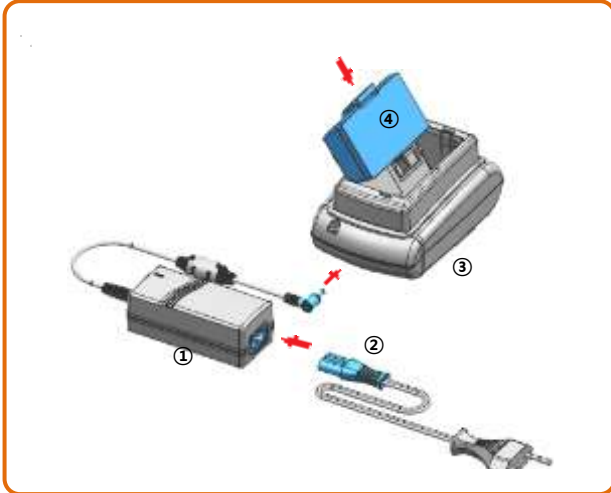
3-2-3 Using Single Battery Charger (Optional)

- 1) Connect the power cord ② to the battery charger ①.
- 2) Connect the battery charger ① to the power port of the cradle ③.
- 3) Plug the power cord ② into an AC power.
- 4) Insert the battery ④ into the cradle ③ a snapping sound is heard.

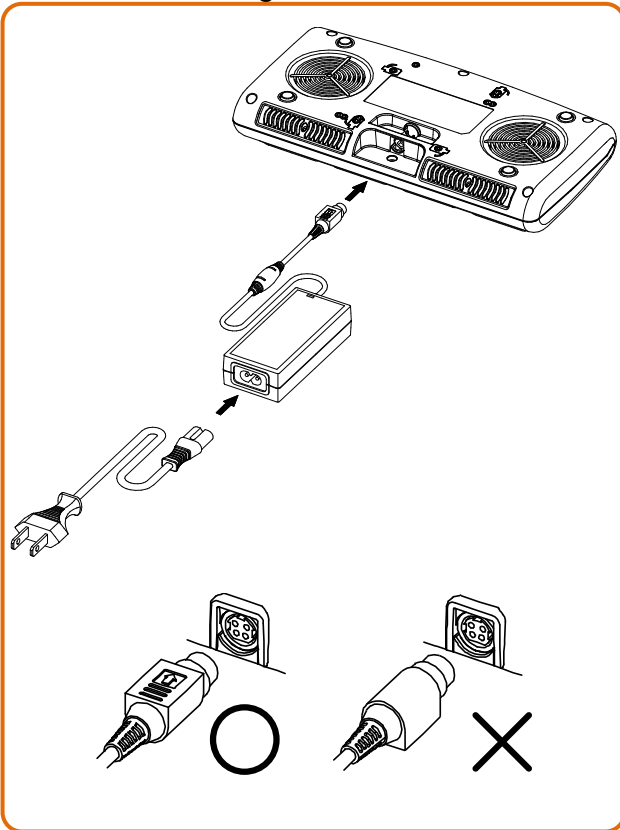

- The printer may incur serious damage if you do not use the battery charger provided by BIXOLON when using a single battery charger. BIXOLON is not legally liable for any such damages.
- You must use the battery charger provided by BIXOLON to use the singles battery charger. (AC/DC adapter is not available)

3-2-4 Using Quad Battery Charger (Optional)**3-2-4-1 Connecting the cables**

- 1) Connect the power cord to the Adapter, and connect the Adapter to the power port of the quad battery charger.
- 2) Plug the power cord into a AC power. Input power is 100 ~ 240 VAC, 50/60 Hz, 1.0 A.
- 3) When the power is supplied, the yellow, green and red LEDs are on for three seconds and do the self-test.

Warning

Use only designated AC/DC Adapter. (12 VDC, 3 A)

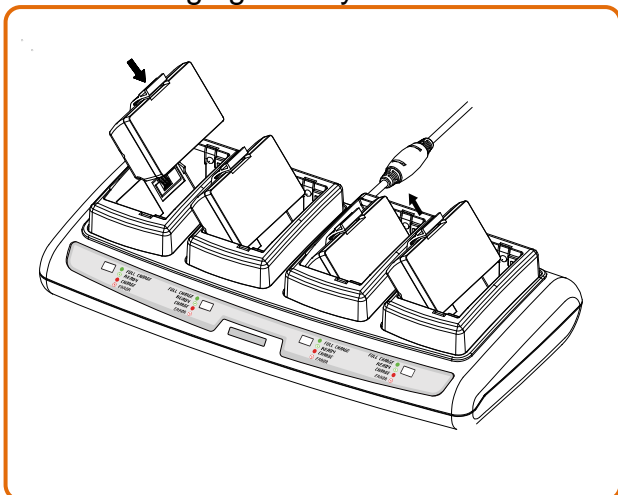
3-2-4-2 Charging Battery

- 1) Insert the battery into the Quad charger as shown in the figure on the left.
- 2) Gently slide the battery until it reaches the bottom of the charger.
- 3) Charging starts as soon as the battery is completely inserted.
- 4) After charging, remove the battery from the Quad charger.

NOTE

Battery charging status descriptions are as follows.

LED	Charge Status	Charge Time
Red LED On	Charging	Within 4 hours
Green LED Blinking	Over 80% Charged	
Green LED On	Fully Charged	
Red LED Blinking	Error Replace or Reinstall Battery	

Warning

- If the red lamp of the charger blinks, install the battery again.
- If the red lamp continues to blink despite several attempts (4 ~ 5 times) to install the battery, contact your local dealer.
- The charging time may vary depending on the type of the charger or ambient temperature.

3-3 Media Installation



1) Press the Open button to open the media cover.



2) After keeping the media holder wide as shown, in the figure insert the media as shown.
(Remove the empty media core.)



3) Check the orientation of the media when inserting it into the printer.



4) Pull out the media as shown and close the media cover.

** NOTE**

The specification of the media inner diameter of the standard media disks are 19 mm (0.75 inch). If you are using media with a smaller inner diameter, remove the media disks as shown below and replace it with the supplied 12 mm (0.47 inch) media disks.

3-4 Using Peeler

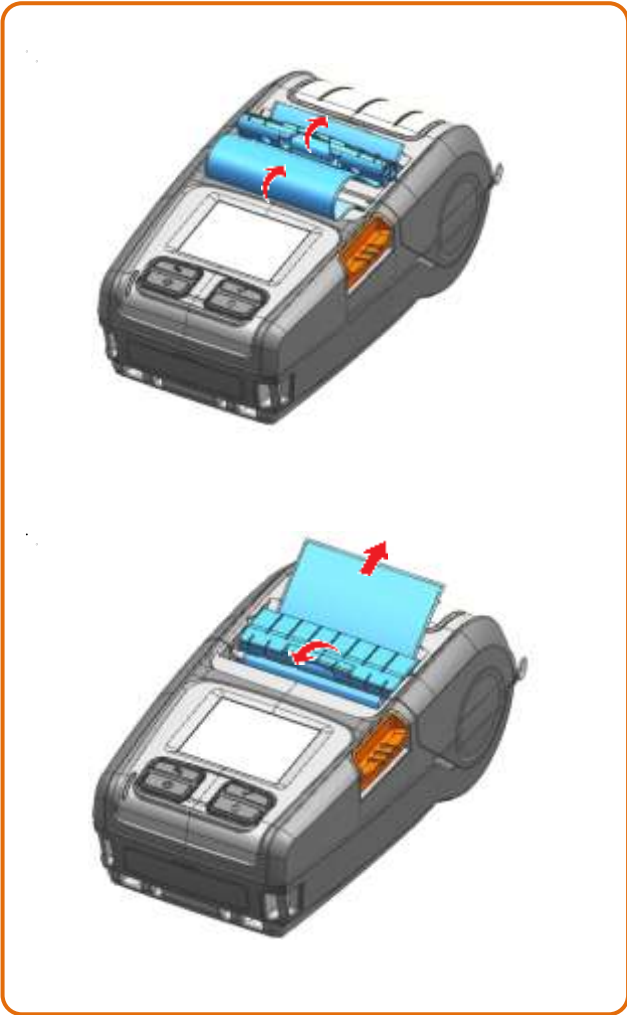

1) Insert the media after open the peeler as shown.

2) Pull out the media after close the peeler as shown.

 NOTE

Enable the peeler setting when using the peeler. Refer to “Sensor setting” of “5. LCD Menu” to enable peeler setting.

3-5 Using Belt Strap



1) Insert the belt strap screw into the belt strap hole.

2) Use a coin to tighten the belt strap screw as shown in the image.

3) Unfasten the belt strap Velcro.

4) Slide the belt strap over a belt.

5) Close the Velcro as shown in the image.

3-6 Using Shoulder Strap (Optional)



Please, insert hooks of the strap into each slot as shown in the picture.

3-7 Using Fan-Fold Media

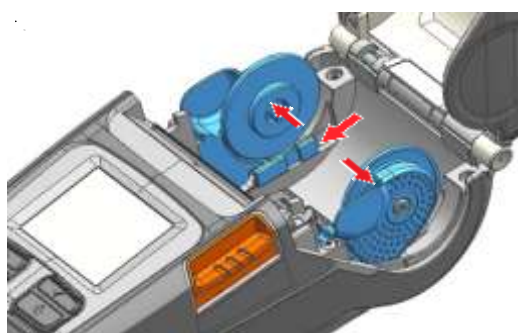
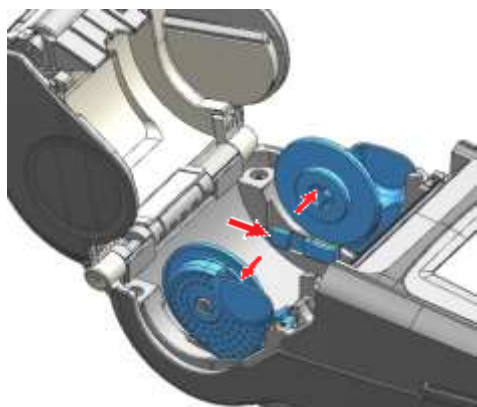

1) After keeping the media holder wide as shown in the figure, hold the media holder by pushing left and right guide holder as shown in the figure.

 NOTE

Use only when you are using 58 mm (2.28 inch) media.

2) Separate the fan-fold cover by pushing as shown in the figure.

3-8 Using Control Panel**• Power Button**

This button is used to turn the printer on, off, to move to main menu or to operate the action.

- 1) When the printer is off, press this button for approximately 2 seconds to turn on the power.
- 2) When the printer is on, press this button for approximately 2 seconds to turn off the power.
- 3) Pressing this button while the LCD menu is being operated moves to the main menu or the action selected in the menu is operated.

• Media Feed Button

This button is used to feed the media manually or return to the previous step.

- 1) Press and hold this button while the printer is booting to print a self-test page.
- 2) Press this button in the standby mode to feed the media.
- 3) Press this button to return to the previous menu.

• Menu Move Button

This button is used to move the LCD menu.

Press this button to move the LCD menu from the top left to the bottom right.

• Menu Select Button

This button is used to select the LCD menu.

Press this button to select the LCD menu or save the selected settings to the printer.

4. Self-Test

Run the self-test to check the setting information when you are setting up the printer for the first time or if there is a problem.

If no issue is found with the printer after running the self-test, examine the other devices or peripherals and software. This function is independent of such other devices and software.

• Self-Test Instructions

- 1) Turn the printer power on and go to the Tool > Print Printer Config menu on the LCD
- 2) Press the power button(Print) to run the self-test.
- 3) The printer settings information is printed on the first page, and the wireless interface information is printed on the next page.
- 4) After the wireless interface information is printed, the self-test is automatically terminated.

• Self-Test Sample

BIXOLON XM7-20 CONFIGURATION	
FIRMWARE VERSION	: V01.00 STD 010118
EMULATION	: SLCS & BPL-Z & BPL-C
PRINT DARKNESS	: 0/30
PRINT SPEED	: 5 IPS
TEAR OFF VALUE	: +000 DOT
TEAR OPTION	: TEAR-OFF
PRINT OFFSET	: +0000 DOT
POWER-UP ACTION	: NO ACTION
MEDIA TYPE	: BLACKMARK MEDIA(REAR)
SENSOR TYPE	: REAR REFLECT
PRINT METHOD	: DIRECT THERMAL
LABEL LENGTH	: 1013 DOT
LABEL WIDTH	: 576 DOT
BAUD RATE	: 115200
PARITY	: NONE
DATA BIT(S)	: 8
STOP BIT(S)	: 1
HAND SHAKING	: HARDWARE
USB SERIAL NUMBER	: 0000000000001
BPL-Z CODEPAGE	: CP-850(SBE. USA-1 CHARSET)
SLCS CODEPAGE	: WCP1252-LATIN1
SLCS ICS	: U.S.A
CONFIGURATION CONTROL STATUS	
PRINT SPEED	: COMMAND
PRINT DARKNESS	: COMMAND
PRINT WIDTH	: COMMAND
PRINT OFFSET	: COMMAND
TEAR OFF	: COMMAND
MEDIA TYPE	: COMMAND
LANGUAGE	: COMMAND

(Bluetooth)

RF INTERFACE STATUS (BT)

BLUETOOTH F/W VER : 2.0.4
MAC ADDRESS



74F07DE3D121

FRIENDLY NAME : XM7-20
MODE : CLASSIC
AUTH & ENCRYPT : ENABLED
CONNECTION MODE : 2

(Wireless LAN)

RF INTERFACE STATUS (WLAN)

WLAN F/W VER : 02.02(4002)
MAC ADDRESS



74F07DE3D121

SYSTEM NAME : XM7-20
NETWORK MODE : SOFT AP
FREQUENCY : (PRIORITY)2.4GHZ/5GHZ
AUTHENTICATION : OPEN
ENCRYPTION : NONE
ESSID : PRINTER_E3D121
DHCP : DISABLED
IP ADDRESS : 192.168.1.1
NETMASK : 255.255.255.0
GATEWAY : 192.168.1.2
PORT : 9100
INACTIVITY TIME : 10 SEC

5. LCD Menu





You can check printer status and setting information through LCD.





• **Top icon**

Icon	Description
	Bluetooth is enabled but not connected to the host device
	Bluetooth is enabled and connected to the host device
	Display signal strength of wireless LAN
	Can not searching the registered AP
	Authentication failed
	Ethernet is enabled and connected
	Receiving data, printing or media feed
	Media out
	Media cover open
	Printer over temperature
	Battery status

• **Main menu icon**

Icon	Description
	Check / set the status of whole printer 1) Interface 2) Media 3) Sensor 4) Powersave 5) Language
	Media settings 1) Print density 2) Position - Tear off position - Print position - Print direction
	Tools 1) Hex dump 2) Print printer config → Self test 3) Print test pattern 4) Printer factory reset
	Check / set the status of the interface 1) Bluetooth - On/Off - SSP (Secure Simple Pairing) / PIN code mode setting - BLE / Classic mode setting - Information (Name, MAC address) 2) Wireless LAN - On/Off - Information (SSID, Mode, Encryprtion, IP, Port, MAC address, Inactivity time) - Smart connection (easy connection to AP by linking with smart connection APP) - WLAN Factory reset 3) Ethernet - On/Off - Information (IP, Port, MAC address, Inactivity time)
	Check the battery status

Icon	Description
	Check printer information 1) Version - Printer, WLAN, Bluetooth 2) Bluetooth 3) WLAN 4) Ethernet 5) Battery 6) Troubleshooting
	Sensor settings 1) Media type - Auto detection / Rear black mark / Gap - Continuous 2) Peeler - On/Off - Sensor sensitivity adjustment
	Set Backlight, Sleep and Power off Time 1) Backlight brightness 2) Backlight off time 3) Sleep time 4) Power off time

6. Peripherals Connection

This product can communicate with other devices via Bluetooth, Wireless LAN communication and cable.

6-1 Bluetooth, Wireless LAN Connection



- 1) The printer can be connected to devices equipped with Bluetooth communication capacity (PDAs, PCs, etc.).
- 2) Use the Bluetooth connection function supported by the device to connect to the printer.
The NFC tag built into the printer enables automatic pairing with devices.

 **NOTE**

Tap your host device to logo on the side of the printer for NFC auto pairing



 **NOTE**

The device must support NFC Auto Pairing. It may display a message that the device cannot be connected as NFC Auto Pairing is supported up to the Bluetooth pairing and the devices must be connected manually, but this is normal.

- 3) The printer can be connected to other stations, such as PDAs and PCs supporting wireless LAN communication in Ad-hoc mode, Soft AP mode and AP in Infrastructure mode.

 **NOTE**

Refer to the Bluetooth & Wi-Fi Connection Manual for detailed information on its connection.

You can check the bluetooth environment (authentication, encryption, connection mode) and the wireless LAN environment (IP, SSID, authentication, encryption) via the self-test page.

6-2 Interface Cable Connection



- 1) Open the Interface Cap ①.
- 2) Connect the external communication cable ② to the cable port of the printer.
- 3) Connect the interface cable to the USB port of the device (PDAs, PCs, etc.).

 NOTE

The interface cable that can be connected to the printer is Serial/USB cable provided by BIXOLON(optional) or USB Type-C cable supporting USB2.0.

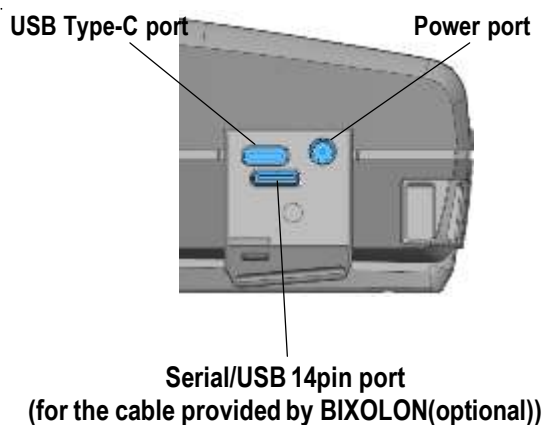

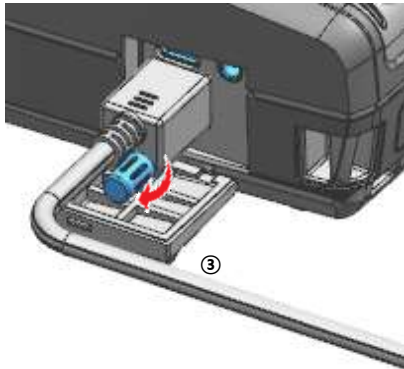
6-3 Fixed Interface Cable Connection

- 1) Open the Interface Cap ①.
- 2) Connect the external communication cable (optional) ② to the cable port of the printer.
- 3) Fix the interface cable by tightening the screw ③ as shown in the figure.
- 4) Connect the interface cable to the USB port of the device (PDAs, PCs, etc.).

 NOTE



The fixed interface cable that can be connected to the printer is Serial/USB cable provided by BIXOLON(optional).

7. Printer Cleaning

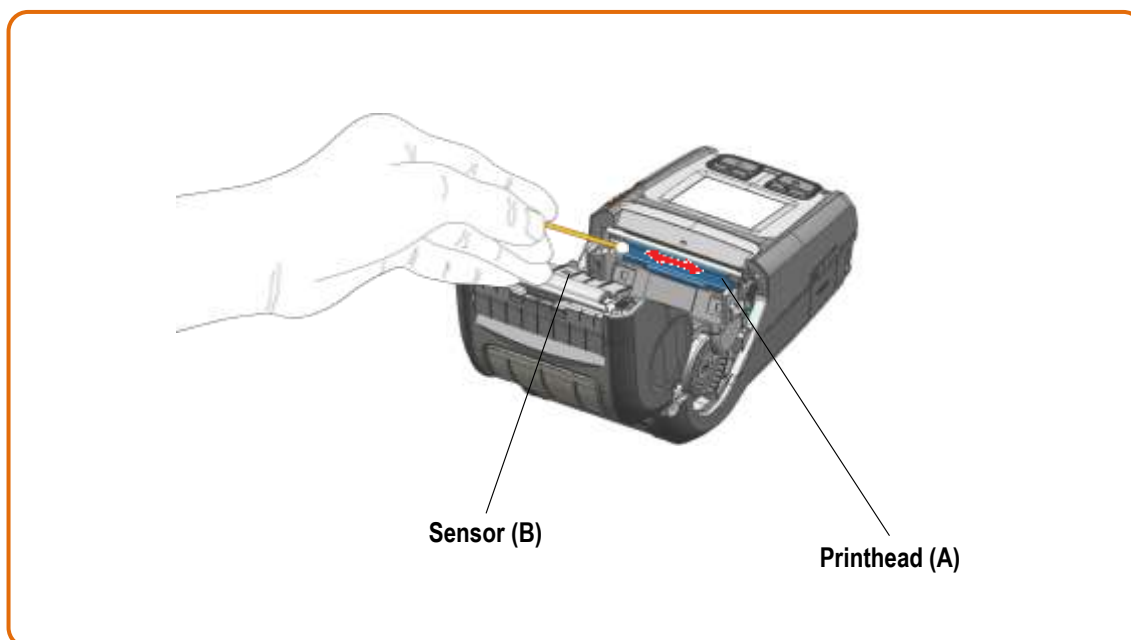
If the interior of the printer is dusty, print quality can decline. In such a case, follow the instructions below to clean the printer.



- 1) Open the media cover and remove the media, if present.
- 2) Clean the printhead (A) using the cloth or cotton swab soaked in alcohol for medical.
- 3) Using the cloth or cotton swab soaked in alcohol for medical, remove the media dust from the black mark sensor (B).
(Sensor could be located in the middle or on left or on right)
- 4) Do not use the printer for one to two minutes after cleaning until the alcohol for medical has completely evaporated and dried.
- 5) Insert the media and close the media cover.

 Caution	<ul style="list-style-type: none"> • Make sure the printer power is turned off before cleaning. • Wait for two to three minutes after power-off before printhead cleaning because it may be very hot. • Do not touch the heating region of the printhead with your hand while cleaning it. • The printhead may be damaged by static electricity. • Avoid scratching the printhead. • Clean the printhead periodically if linerless media is used. Recommended cleaning period is after consuming four rolls of linerless media (100 meters), or approximately once a week. Print quality may be degraded or printhead life may be shortened if it is not cleaned periodically.
 Warning	<p>Use only the linerless media that is provided by BIXOLON. Use of unauthorized media voids product warranty.</p>

8-2 Label Types

- The labels used on this product are composed of the following materials;
 - BIXOLON logo label: PC
 - Rating Label: PET
 - Other labels: PET, PC

Copyright

© BIXOLON Co., Ltd. All rights reserved.

This user manual and all property of the product are protected under copyright law. It is strictly prohibited to copy, store, and transmit the whole or any part of the manual and any property of the product without the prior written approval of BIXOLON Co., Ltd. The information contained herein is designed only for use with this BIXOLON product. BIXOLON is not responsible for any direct or indirect damages, arising from or related to use of this information.

- The BIXOLON logo is the registered trademark of BIXOLON Co., Ltd.
- All other brand or product names are trademarks of their respective companies or organizations.

BIXOLON maintains ongoing efforts to enhance and upgrade the functions and quality of all our products.

In the following, product specifications and/or user manual content may be changed without prior notice.

Warning - U.S.A

This equipment has been tested and found to comply with the limits for a Class A digital device pursuant to Part 15 of the FCC Rules. These limits are designed to provide reasonable protection against harmful interference when the equipment is operated in a commercial environment. This equipment generates uses, and can radiate radio frequency energy and, if not installed and used in accordance with the instruction manual, may cause harmful interference to radio communications. Operation of this equipment in a residential area is likely to cause harmful interference in which case the user will be required to correct the interference at his own expense.

ii) Changes or modifications not expressly approved by the manufacturer could void the user's authority to operate the equipment.

iii) Caution: Exposure to Radio Frequency Radiation.

To comply with FCC RF exposure compliance requirements, a separation distance of at least 20 cm must be maintained between the antenna of this device and all persons.

Notice - Canada

i) Class A Digital Device : Wired Device

This Apparatus complies with class "A" limits for radio interference as specified in the Canadian department of communications radio interference regulations.

Get appareil est conforme aux normes class "A" d'interference radio tel que specifier par ministre canadien des communications dans les reglements d'interference radio.

Caution

Some semiconductor devices are easily damaged by static electricity. You should turn the printer “OFF”, before you connect or remove the cables on the rear side, in order to guard the printer against the static electricity. If the printer is damaged by the static electricity, you should turn the printer “OFF”.

Waste Electrical and Electric Equipment (WEEE)



This marking shown on the product or its literature, indicates that it should not be disposed with other household wastes at the end of its working life. To prevent possible harm to the environment or human health from uncontrolled waste disposal, please separate this from other types of wastes and recycle it responsibly to promote the sustainable reuse of material resources. Household users should contact either the retailer where they purchased this product, or their local government office, for details of where and how they can take this item for environmentally safe recycling. Business users should contact their supplier and check the terms and conditions of the purchase contract. This product should not be mixed with other commercial wastes for disposal.

